

P:\Projects\2023\23101 - RTG Belltown MOB\23101 - RTG-Belltown-Center-Schematic-Landscape.pln

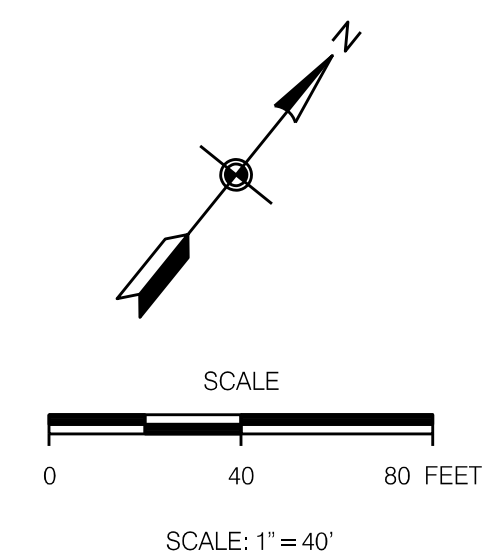
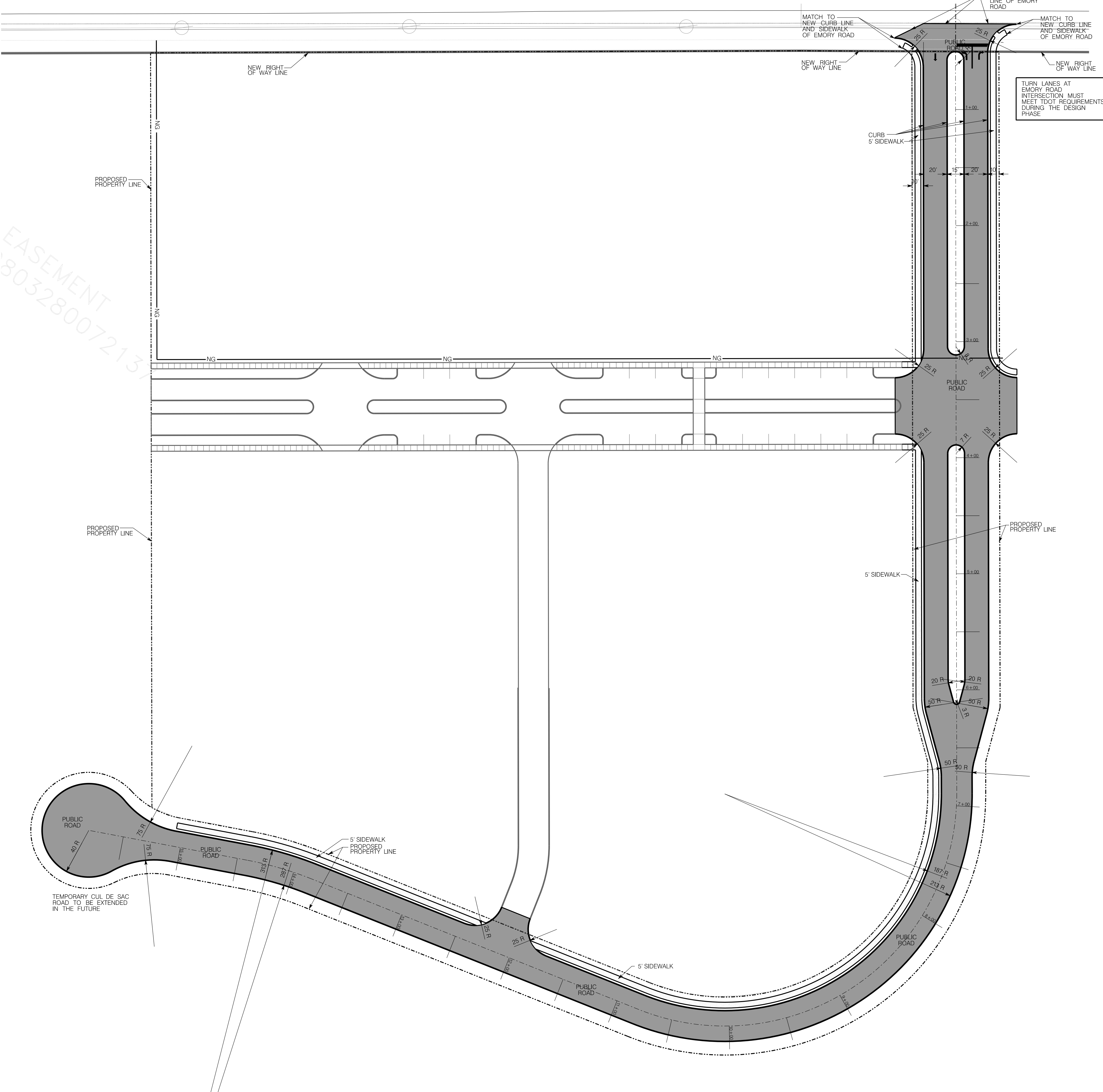

**LEGEND:**

EXISTING	PROPOSED	
--- 535 ---	--- 535 ---	GROUND CONTOUR ELEVATION
--- 535.25' ---	--- 535.25' ---	SPOT ELEVATION
[ ]	[ ]	STRUCTURE
---	---	PROPERTY LINE
---	---	EASEMENT
---	---	EDGE OF PAVEMENT
---	---	STORM DRAIN
---	---	SANITARY SEWER
---	---	POTABLE WATER
---	---	NATURAL GAS
---	---	OVERHEAD ELECTRICAL
(W)	(W)	WATER METER
+	+	FIRE HYDRANT
---	---	SURFACE FLOW
---	---	SILT FENCING
---	---	CURB
---	---	CATCH BASIN
---	---	CONCRETE PAVEMENT
---	---	ASPHALT PAVEMENT
---	---	RIP RAP

CERTIFICATION OF CONCEPT PLAN BY REGISTERED ENGINEER

I HEREBY CERTIFY THAT I AM A REGISTERED ENGINEER LICENSED TO PRACTICE ENGINEERING UNDER THE LAWS OF THE STATE OF TENNESSEE. I FURTHER CERTIFY THAT THE PLAN AND ACCOMPANYING DRAWINGS, DOCUMENTS AND STATEMENTS CONFORM TO THE BEST OF MY KNOWLEDGE, TO ALL APPLICABLE PROVISIONS OF THE KNOXVILLE-KNOX COUNTY SUBDIVISION REGULATIONS EXCEPT AS HAS BEEN ITEMIZED AND DESCRIBED IN A REPORT FILED WITH THE PLANNING COMMISSION.

REGISTERED ENGINEER: WILLIAM N. ROBINSON  
 TENNESSEE LICENSE NUMBER: 101025  
 DATE: 06/24/2024

*William N. Robinson*

**PROJECT DATA**  
 USE: COMMERCIAL MIXED USE DEVELOPMENT  
 ZONING: PLANNED DEVELOPMENT  
 PARCELS: PART OF PARCEL 066 121 AND 066 122  
 PARCEL AREA: 489,644 SF (11.24 AC)  
 IMPERVIOUS AREA: 266,961 SF (6.13 ACRE)  
 IMPERVIOUS AREA RATIO: 54.5 %  
 ALTERNATIVE DESIGN STANDARDS REQUESTED:  
 HORIZONTAL CURVE RADII (250 FT TO 200')  
 INTERSECTION GRADE (1% TO 2%)  
 PUBLIC WATER AND SEWER AVAILABLE FOR THIS PARCEL FROM HALLSDALE POWELL UTILITY DISTRICT GAS IS AVAILABLE FOR FOR THIS PARCEL FROM KNOXVILLE UTILITIES BOARD

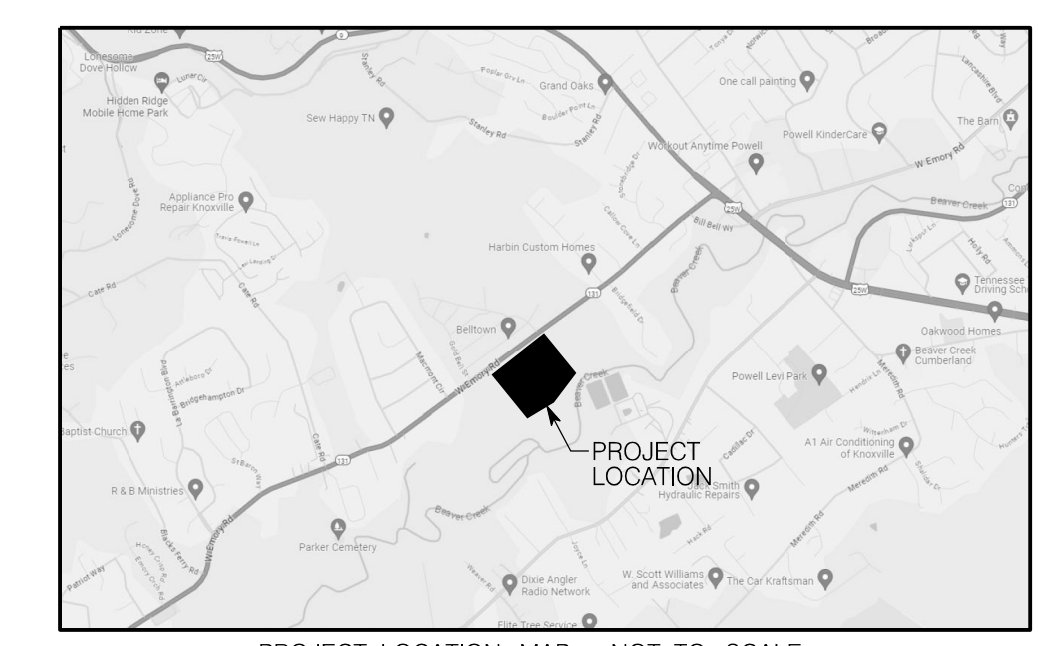

**GEORGE ARMOUR EWART ARCHITECT**  
 404 Bearden Park Circle  
 Knoxville, TN 37919  
 865.602.7771  
 Fax 865.602.7742  
 www.georgeewart.com

PLAN DEVELOPMENT  
**BELTOWN CENTER**  
 4720 W. EMORY RD  
 POWELL, KNOX COUNTY  
 TN 37849  
 7-SD-24-C

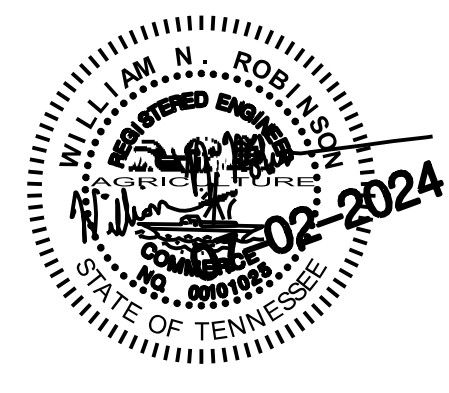

CONCEPT LAYOUT PLAN

DATE: 7/02/2024  
 PROJECT NO.: 23101  
 PROJECT MGR.: G.E.

PL01

7-SD-24-C  
 Revised: 7/2/2024



P:\Projects\2023\23101 - RTG Belltown MOB\23101 - RTG-Belltown-Center-Schematic-Landscape.pln

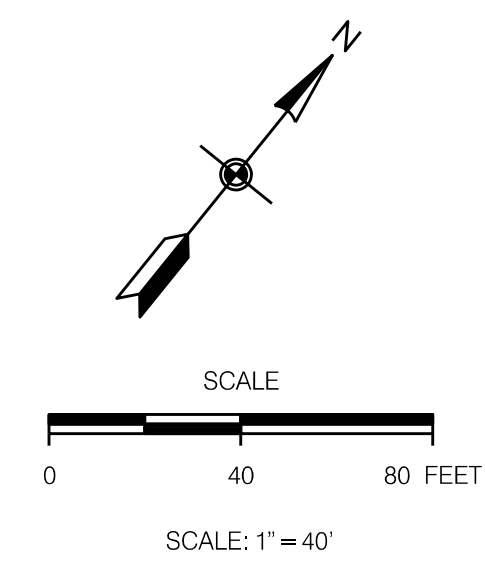
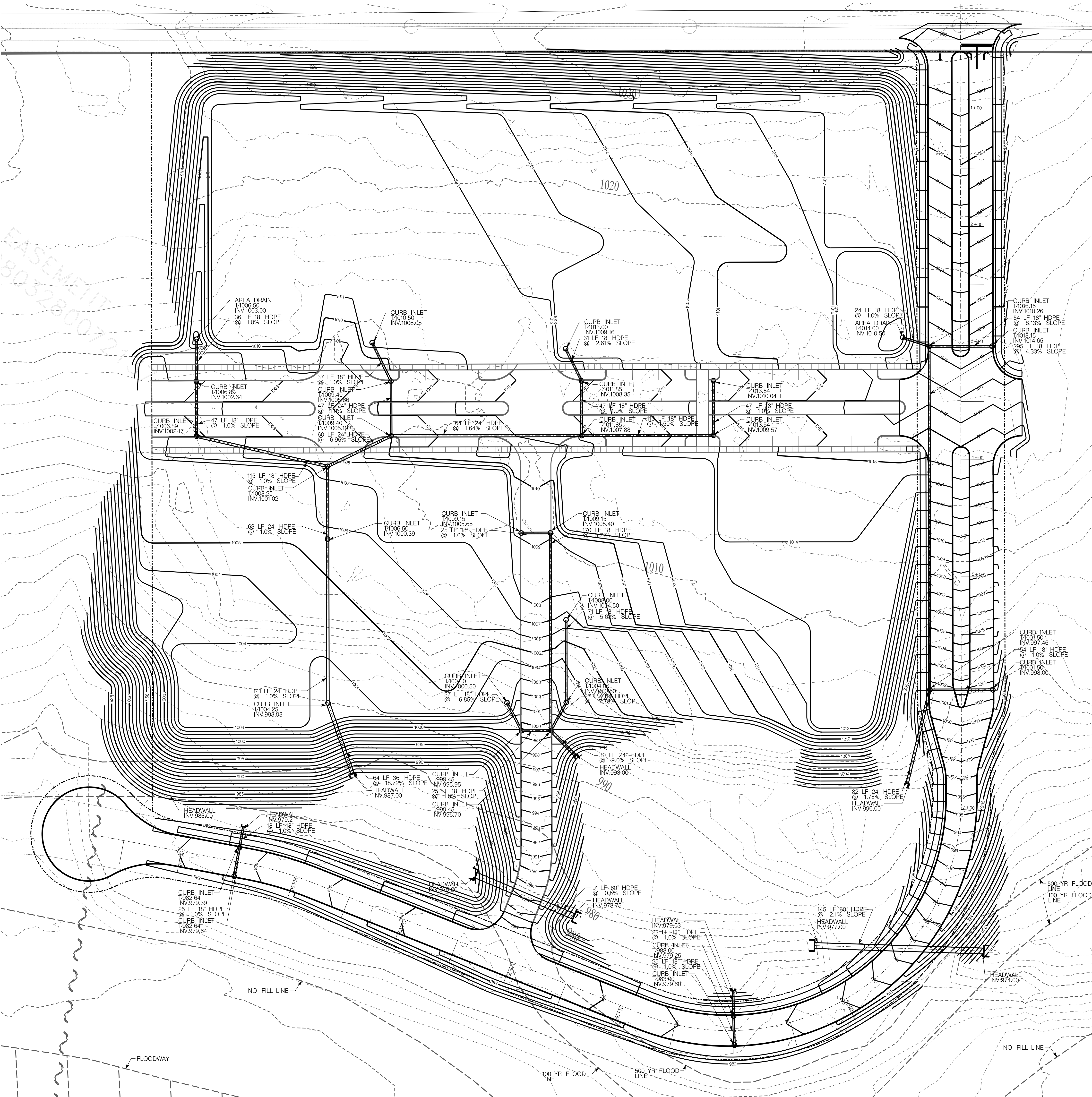

**LEGEND:**

EXISTING	PROPOSED	DESCRIPTION
535	535	GROUND CONTOUR ELEVATION
535.25'	535.25'	SPOT ELEVATION
[Symbol]	[Symbol]	STRUCTURE
[Symbol]	NA	PROPERTY LINE
[Symbol]	NA	EASEMENT
[Symbol]	[Symbol]	EDGE OF PAVEMENT
SD	SD	STORM DRAIN
SS	SS	SANITARY SEWER
PW	PW	POTABLE WATER
NG	NG	NATURAL GAS
OE	OE	OVERHEAD ELECTRICAL
(W)	(W)	WATER METER
[Symbol]	NA	FIRE HYDRANT
NA	[Symbol]	SURFACE FLOW
NA	[Symbol]	SILT FENCING
[Symbol]	[Symbol]	CURB
NA	[Symbol]	CATCH BASIN
NA	[Symbol]	CONCRETE PAVEMENT
NA	[Symbol]	ASPHALT PAVEMENT
NA	[Symbol]	RIP RAP

**GEORGE  
ARMOUR  
EWART  
ARCHITECT**

404 Bearden Park Circle  
Knoxville, TN 37919  
865.602.7771  
Fax 865.602.7742  
www.georgeewart.com

PLAN DEVELOPMENT  
**BELTOWN CENTER**  
4720 W. EMORY RD  
POWELL, KNOX COUNTY  
TN 37849  
7-SD-24-C

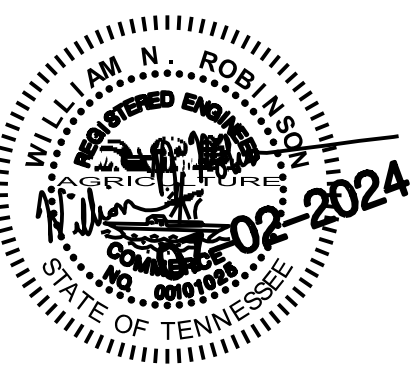

CONCEPT GRADING PLAN

DATE: 7/02/2024  
PROJECT NO.: 23101  
PROJECT MGR.: G.E.

7-SD-24-C  
Revised: 7/2/2024

PL02



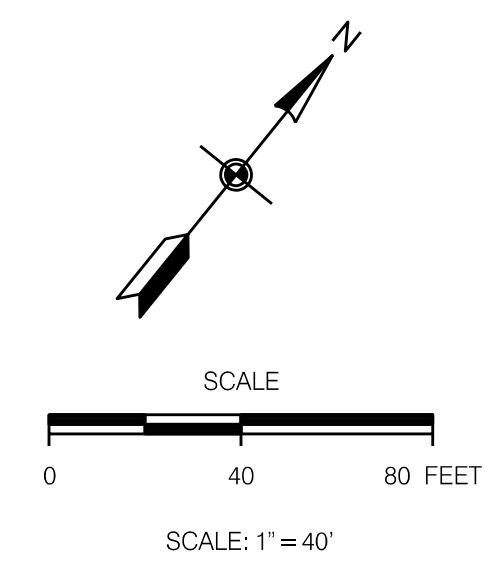
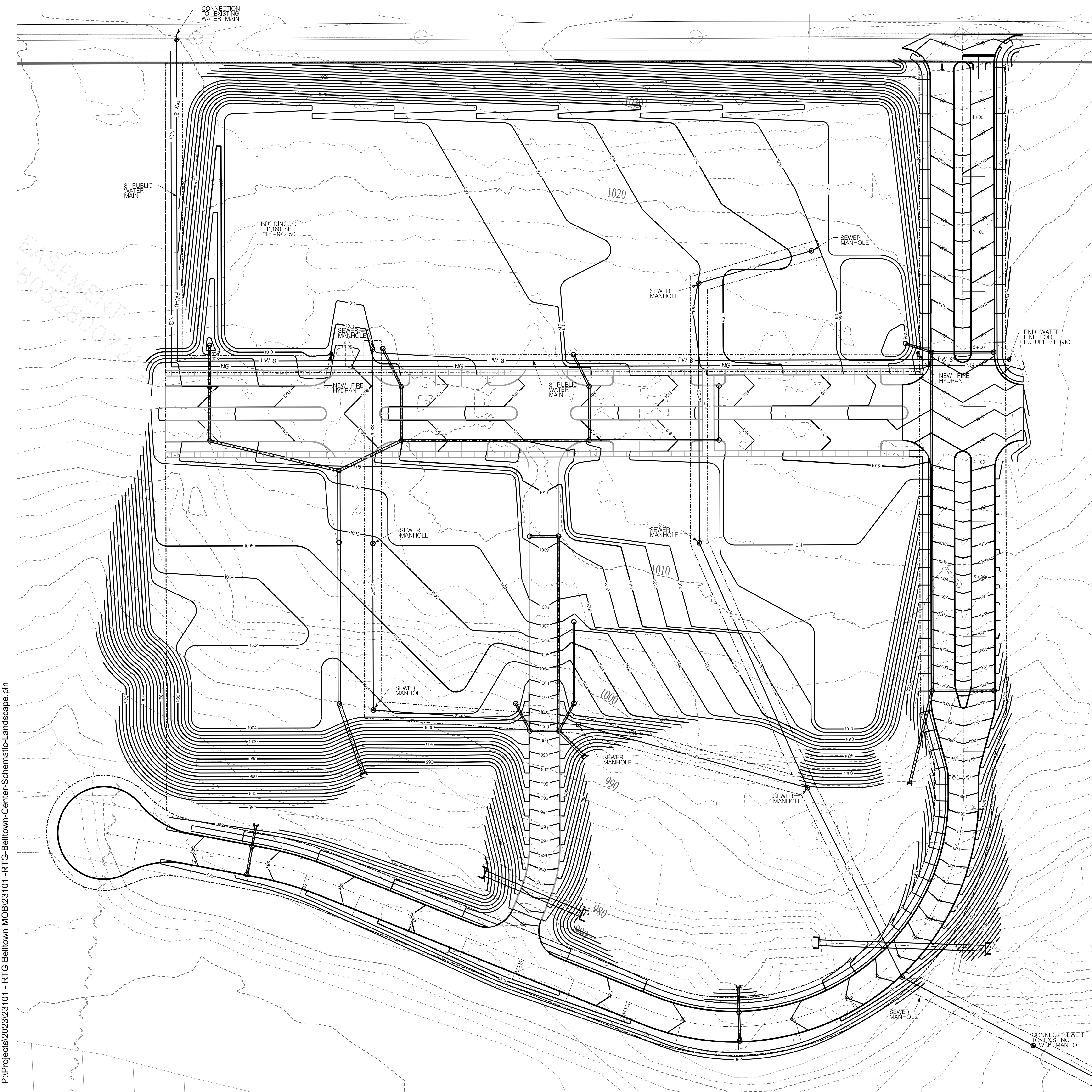

**LEGEND:**

EXISTING	PROPOSED	
535	535	GROUND CONTOUR ELEVATION
535.25'	535.25'	SPOT ELEVATION
[Symbol]	[Symbol]	STRUCTURE
[Symbol]	NA	PROPERTY LINE
[Symbol]	NA	EASEMENT
[Symbol]	[Symbol]	EDGE OF PAVEMENT
SD	SD	STORM DRAIN
SS	SS	SANITARY SEWER
PW	PW	POTABLE WATER
NG	NG	NATURAL GAS
OE	OE	OVERHEAD ELECTRICAL
(W)	(W)	WATER METER
[Symbol]	NA	FIRE HYDRANT
NA	[Symbol]	SURFACE FLOW
NA	[Symbol]	SILT FENCING
[Symbol]	[Symbol]	CURB
[Symbol]	[Symbol]	CATCH BASIN
NA	[Symbol]	CONCRETE PAVEMENT
NA	[Symbol]	ASPHALT PAVEMENT
NA	[Symbol]	RIP RAP

**GEORGE  
ARMOUR  
EWART  
ARCHITECT**

404 Bearden Park Circle  
Knoxville, TN 37919  
865.602.7771  
Fax 865.602.7742  
www.georgeewart.com

PLAN DEVELOPMENT  
**BELLTOWN CENTER**  
4720 W. EMORY RD  
POWELL, KNOX COUNTY  
TN 37849  
7-SD-24-C

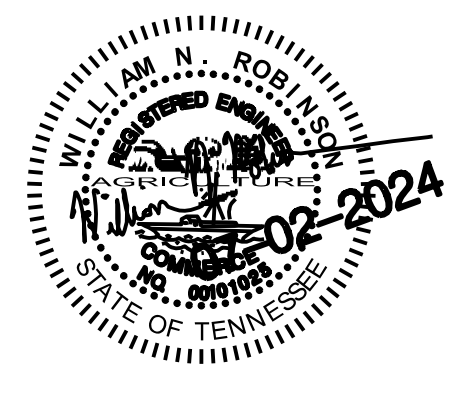

CONCEPT UTILITY PLAN

7-SD-24-C  
Revised: 7/2/2024

DATE: 7/02/2024  
PROJECT NO.: 23101  
PROJECT MGR.: G.E.

PL03

P:\Projects\2023\23101 - RTG Belltown MOB\23101 - RTG-Belltown-Center-Schematic-Landscape.pln



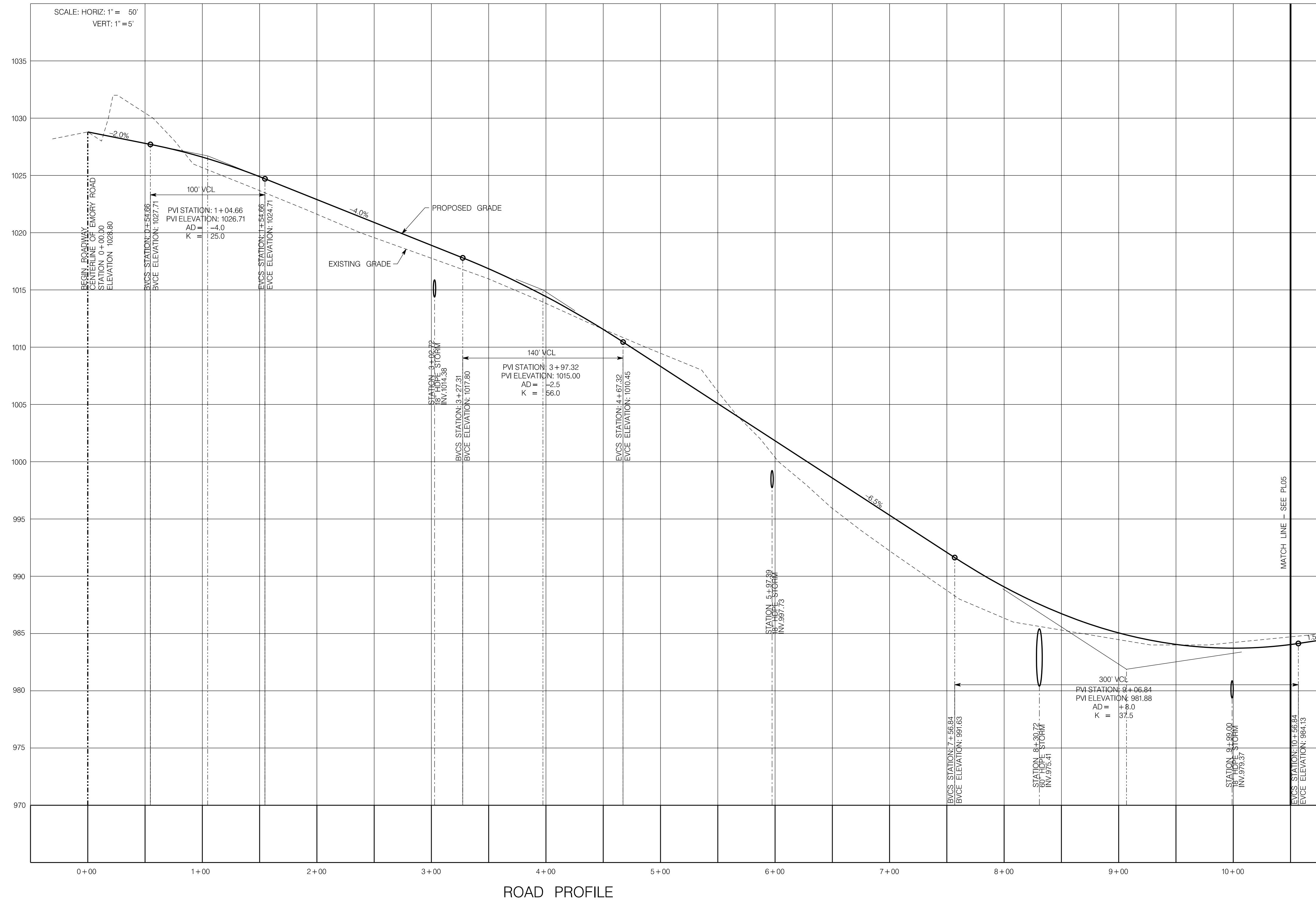

**GEORGE  
ARMOUR  
EWART  
ARCHITECT**

404 Bearden Park Circle  
Knoxville, TN 37919  
865.602.7771  
Fax 865.602.7742  
www.georgeewart.com

PLAN DEVELOPMENT  
**BELTOWN CENTER**  
4720 W. EMORY RD  
POWELL, KNOX COUNTY  
TN 37849  
7-SD-24-C

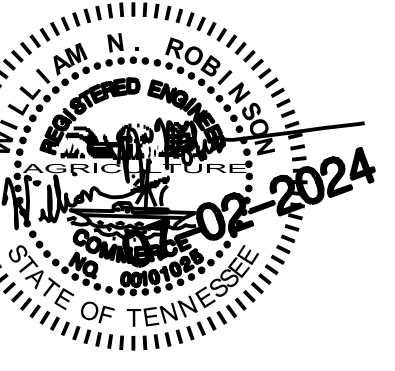

ROAD PROFILE - 1

7-SD-24-C  
Revised: 7/2/2024

DATE: 7/02/2024  
PROJECT NO.: 23101  
PROJECT MGR.: G.E

PL04





**GEORGE  
ARMOUR  
EWART  
ARCHITECT**

404 Bearden Park Circle  
Knoxville, TN 37919  
865.602.7771  
Fax 865.602.7742  
www.georgeewart.com

PLAN DEVELOPMENT  
**BELTOWN CENTER**

4720 W. EMORY RD  
POWELL, KNOX COUNTY  
TN 37849  
7-SD-24-C

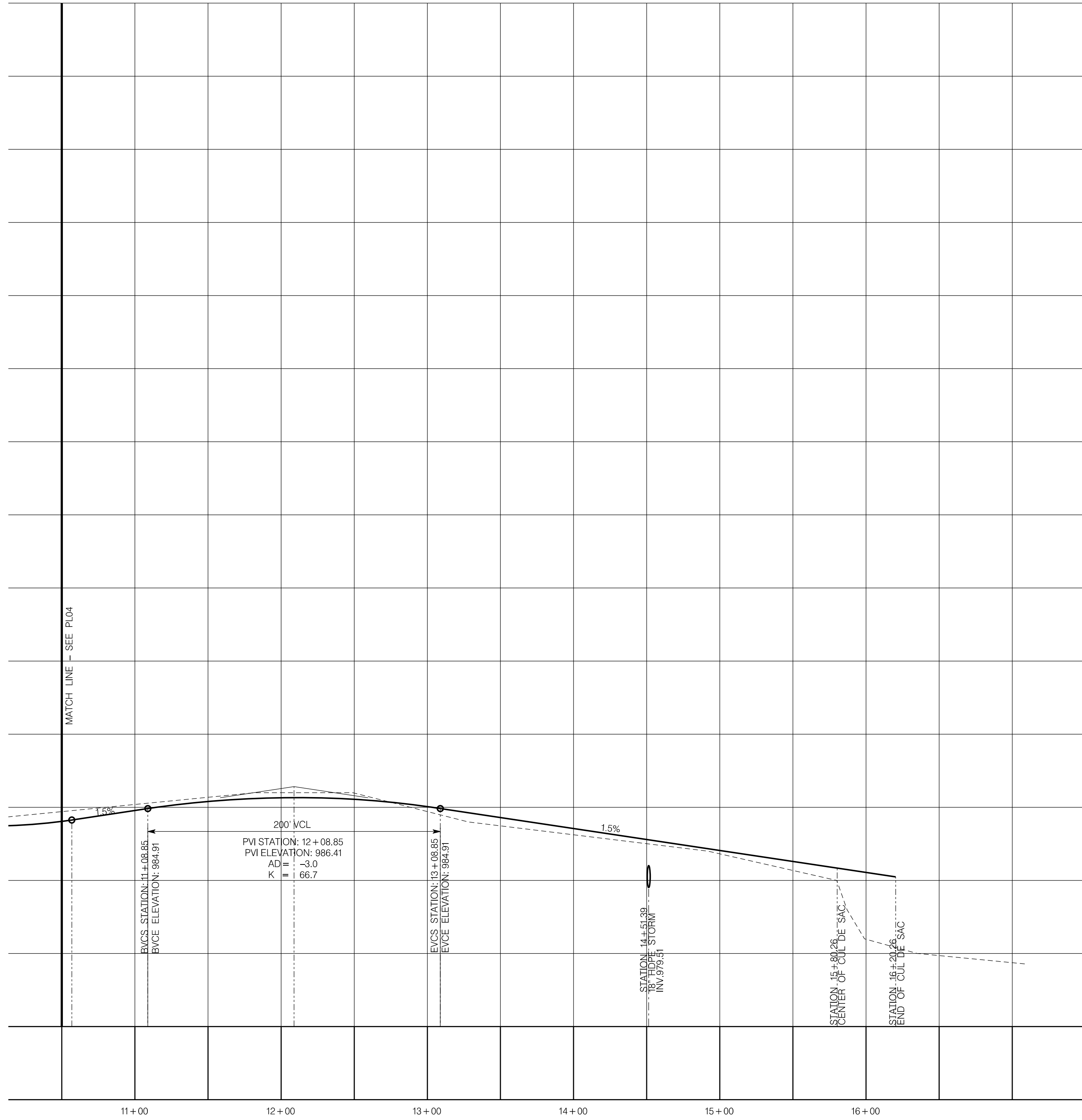
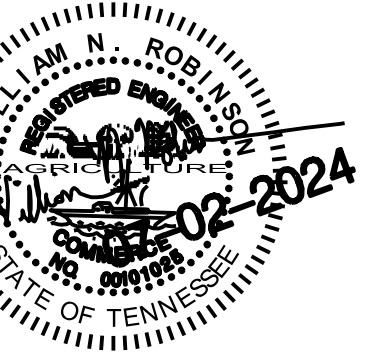

7-SD-24-C  
Revised: 7/2/2024

ROAD PROFILE - 2

DATE: 7/02/2024  
PROJECT NO.: 23101  
PROJECT MGR.: G.E

PL05



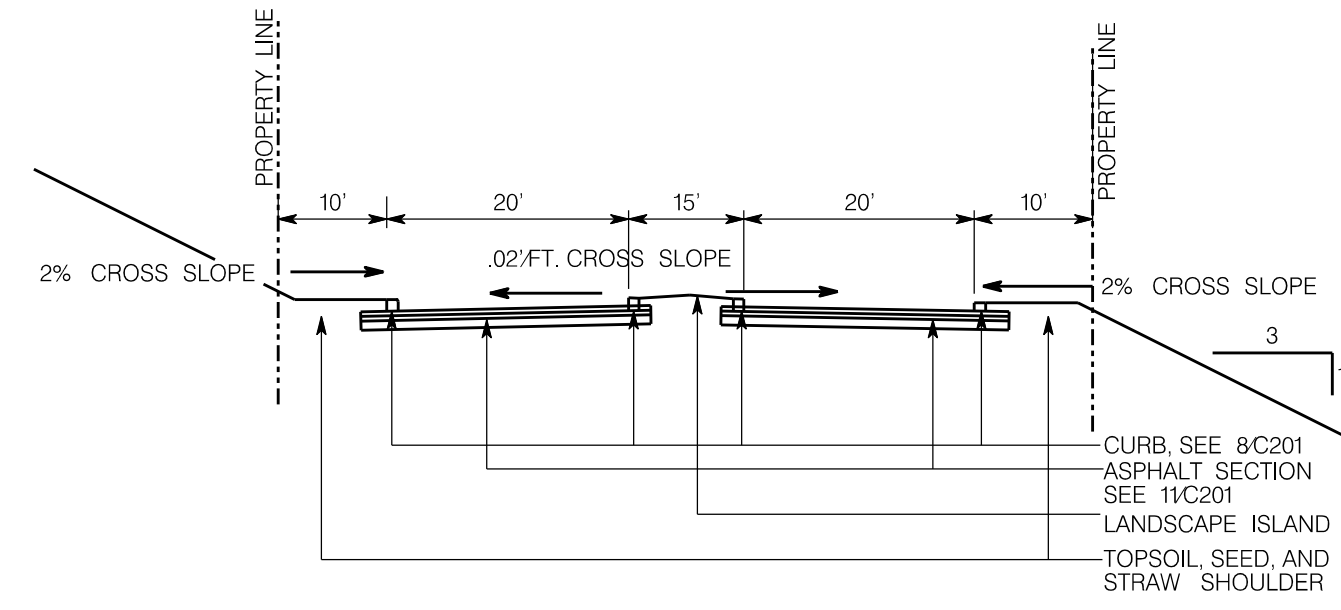

1 PUBLIC ROAD SECTION (DIVIDED)  
PL06 NOT TO SCALE

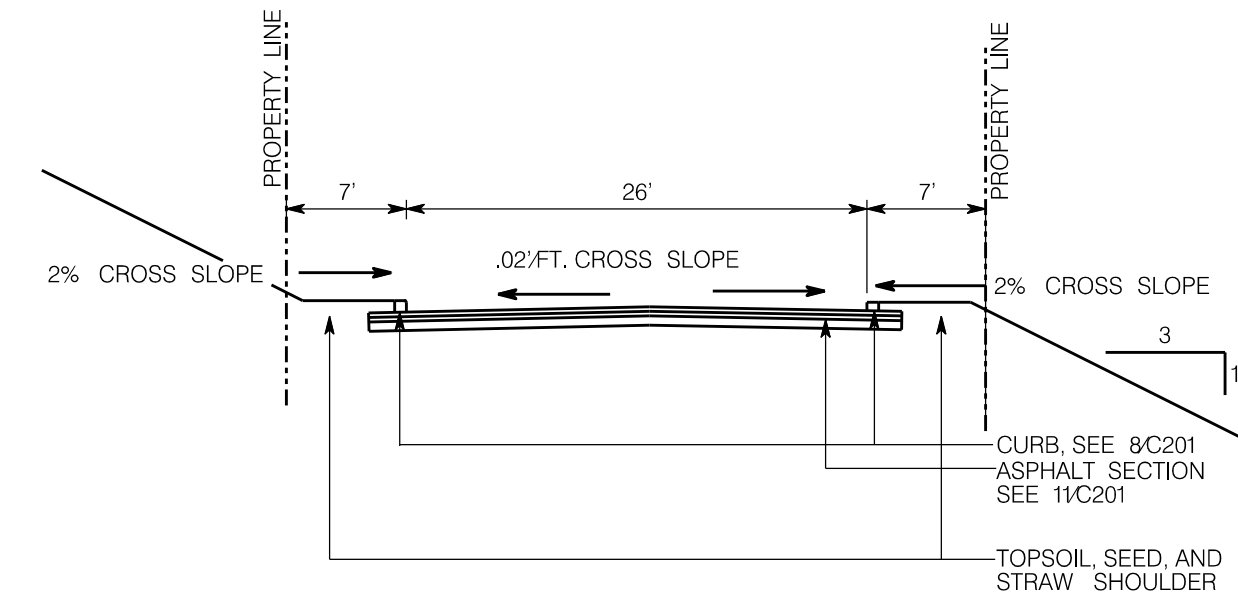

2 PUBLIC ROAD SECTION (STANDARD)  
PL06 NOT TO SCALE



**GEORGE  
ARMOUR  
EWART  
ARCHITECT**

404 Bearden Park Circle  
Knoxville, TN 37919  
865.602.7771  
Fax 865.602.7742  
www.georgeewart.com

PLAN DEVELOPMENT  
**BELLTOWN CENTER**  
4720 W. EMORY RD  
POWELL, KNOX COUNTY  
TN 37849  
7-SD-24-C

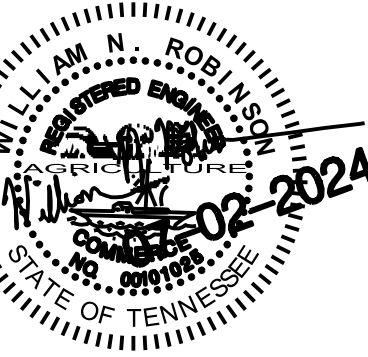

ROAD PROFILE - 2

7-SD-24-C  
Revised: 7/2/2024

DATE: 7/02/2024  
PROJECT NO.: 23101  
PROJECT MGR.: G.E

PL05